

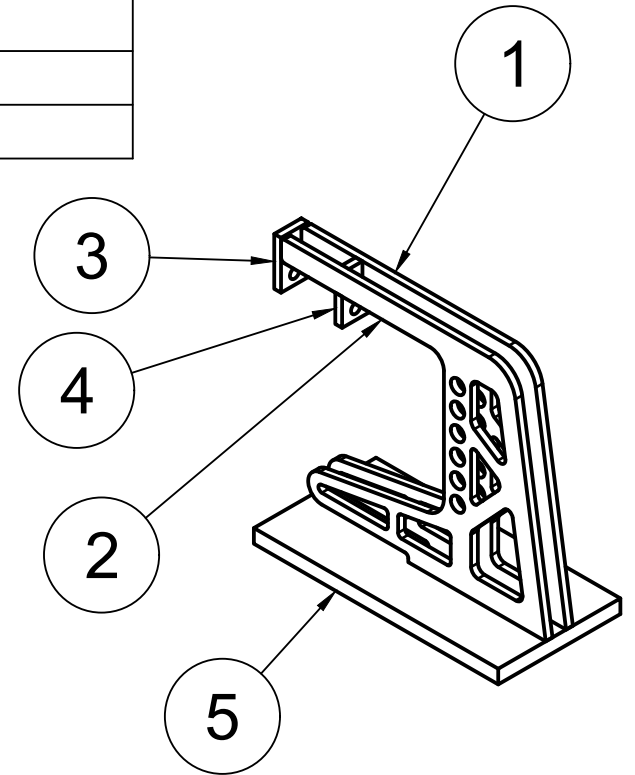

PARTS LIST

ITEM	QTY	PART NUMBER	DESCRIPTION	MATERIAL
1	1	SIDE2		STEEL
2	1	SIDE1		STEEL
3	1	ENDSTOP1		STEEL
4	1	ENDSTOP2		STEEL
5	1	BASE		STEEL

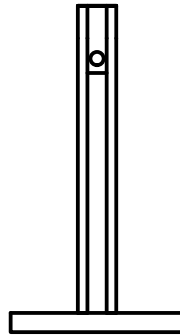
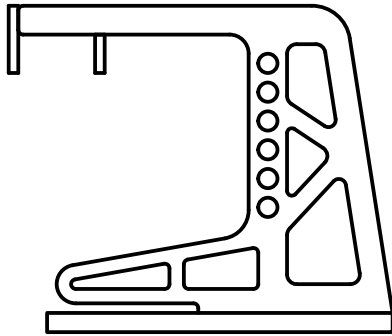
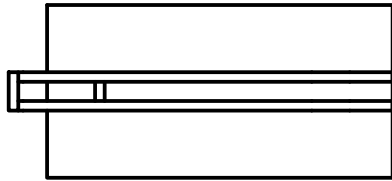

PROJECT

Machining Jigs

TITLE

L-Bracket Bending Fixture

APPROVED

CHECKED

DRAWN

Timothy Long

12/15/18

SIZE

A

CODE

DWG NO

SCALE 1:10

WEIGHT

SHEET 1/5

REV



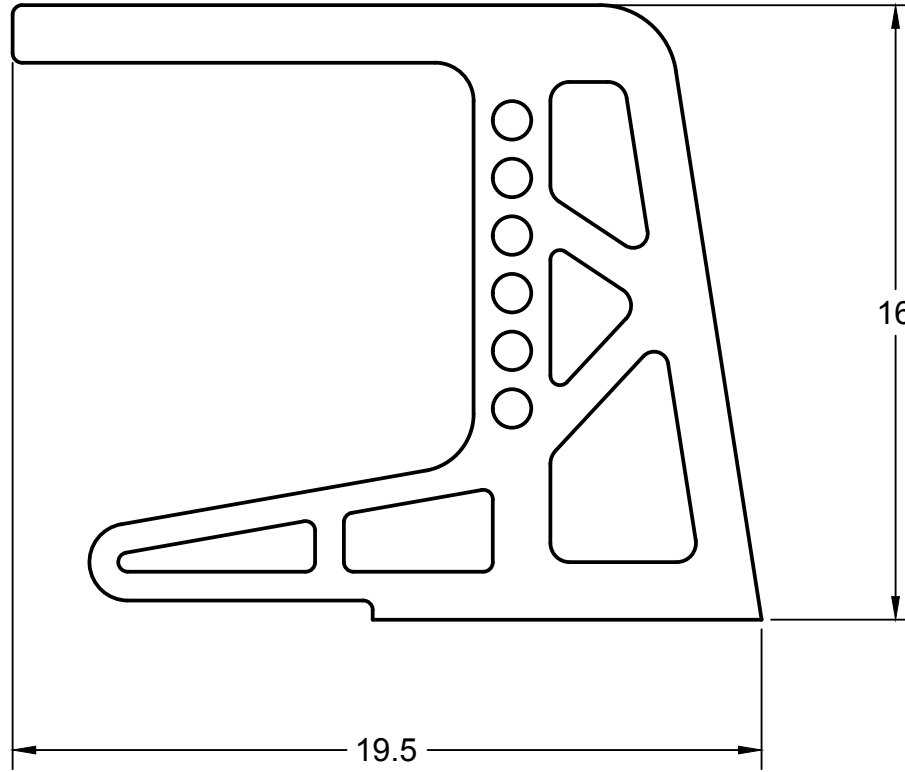

1/2" Steel Plate

	PROJECT			
	Machining Jigs			
	TITLE			
	L-Bracket Bending Fixture			
APPROVED	SIZE	CODE	DWG NO	REV
CHECKED	A			
DRAWN	Timothy Long	12/15/18	SCALE 1:10	WEIGHT
				SHEET 2/5

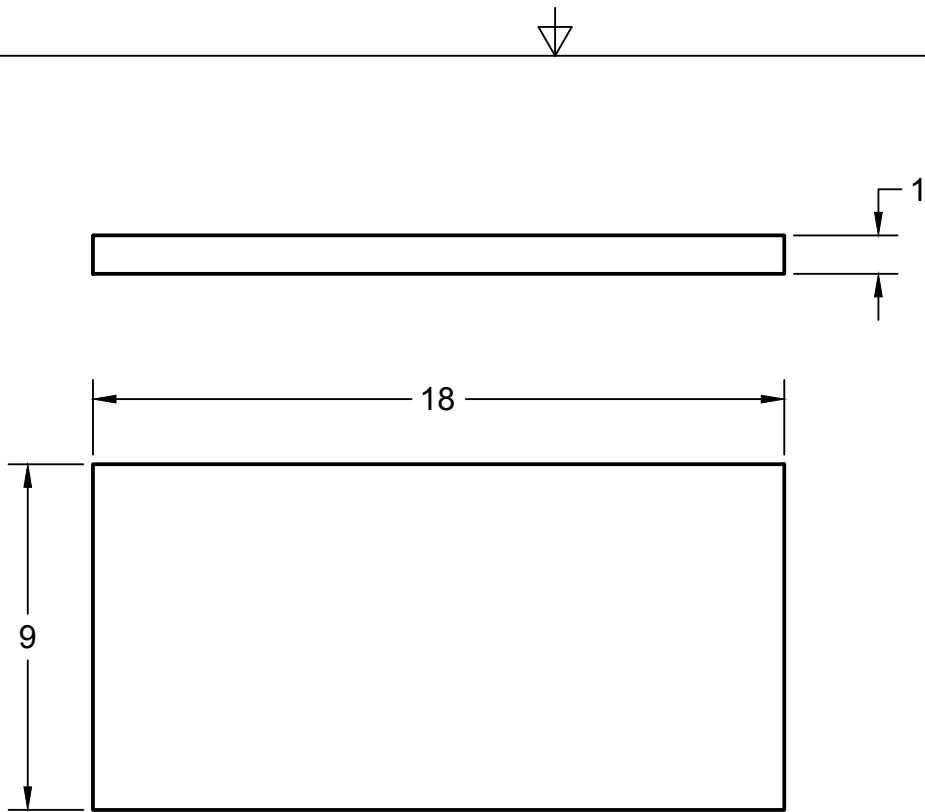

	PROJECT			
	Machining Jigs			
	TITLE			
	L-Bracket Bending Fixture			
APPROVED	SIZE	CODE	DWG NO	REV
CHECKED	A			
DRAWN Timothy Long	12/15/18	SCALE 1:10	WEIGHT	SHEET 3/5

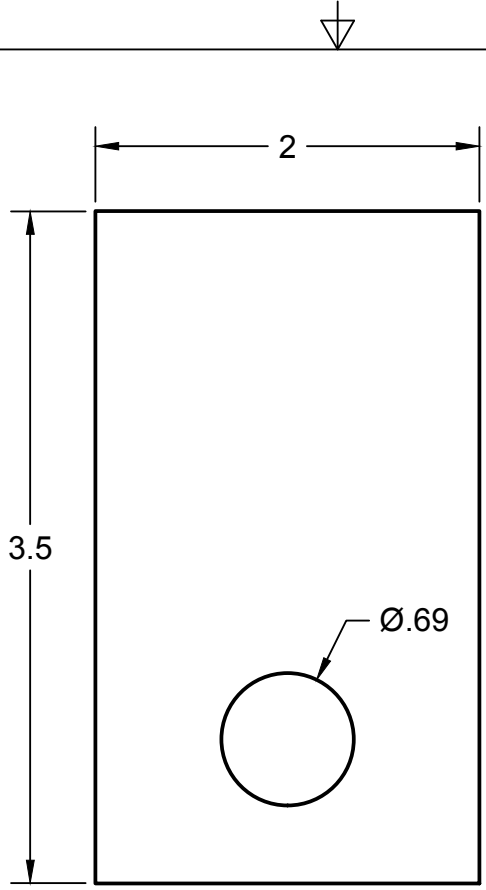

	PROJECT			
	Machining Jigs			
	TITLE			
	L-Bracket Bending Fixture			
APPROVED	SIZE	CODE	DWG NO	REV
CHECKED	A			
DRAWN	Timothy Long	12/15/18	SCALE 1:10	WEIGHT
				SHEET 4/5

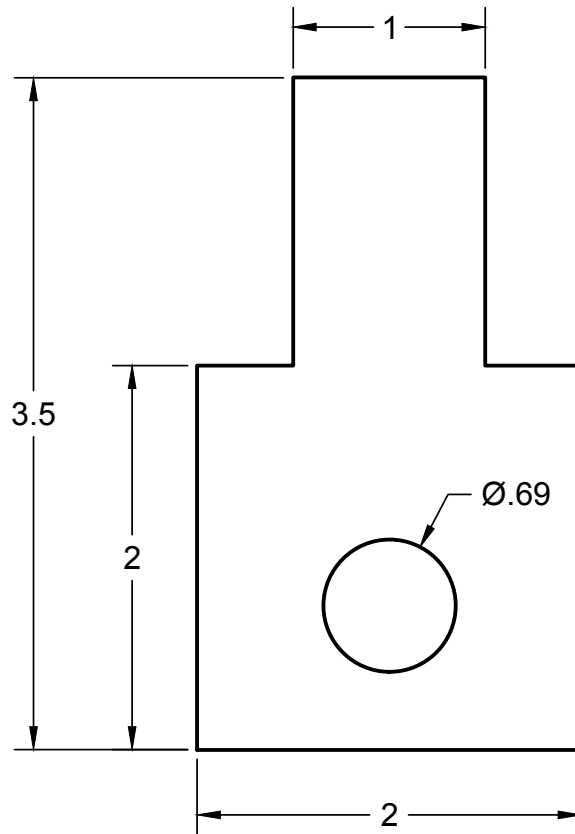

		PROJECT		
		Machining Jigs		
		TITLE		
		L-Bracket Bending Fixture		
APPROVED	SIZE	CODE	DWG NO	REV
CHECKED	A			
DRAWN	Timothy Long	12/15/18	SCALE 1:10	WEIGHT
				SHEET 5/5